



figure **234**

ends form flange straight

BELLOW SEALED STOP VALVE



body material	nominal pressure	nominal diameter	max temperature
A <i>grey cast iron</i>	C 16 bar	DN 15-250	300°C
C <i>nodular cast iron</i>	C 16 bar D 25 bar	DN 15-200	350°C
F <i>cast steel</i>	E 40 bar	DN 15-150	400°C



correspond to the pressure equipment directive 97/23/EC marking CE for Dn≥32

FEATURES

- high tightness (leakproofness class - A acc. EN -12266 - 1)
- compact settlement
- environment-friendly
- tests acc. EN - 12266 - 1
- flanges drilled according to EN 1092-2 for body material A, C
- flanges drilled according to EN 1092-1 for body material F
- face-to-face dimension according to EN 558-1 series 1

APPLICATION

- hot and cold water plants
- steam plants
- neutral fluids

Data given can be changed without notice.

Edition 04/2012

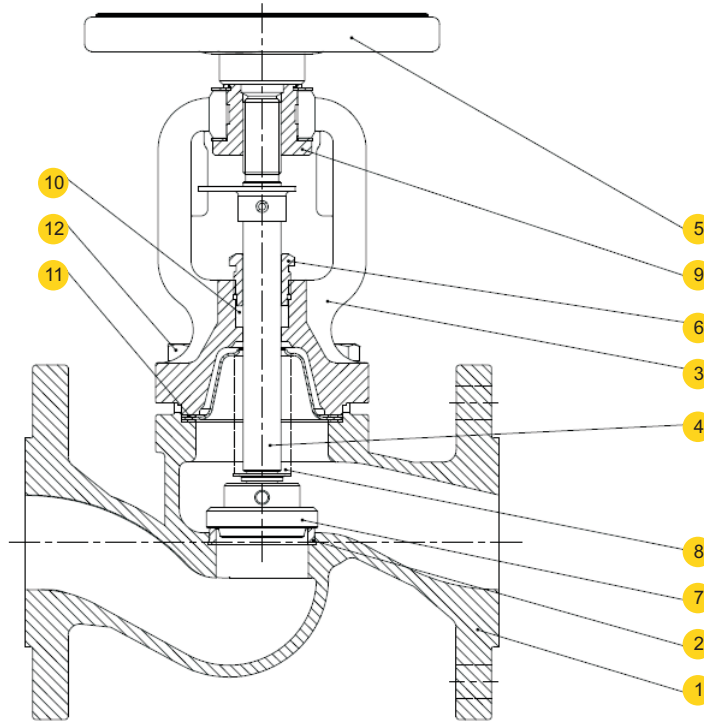


figure **234**

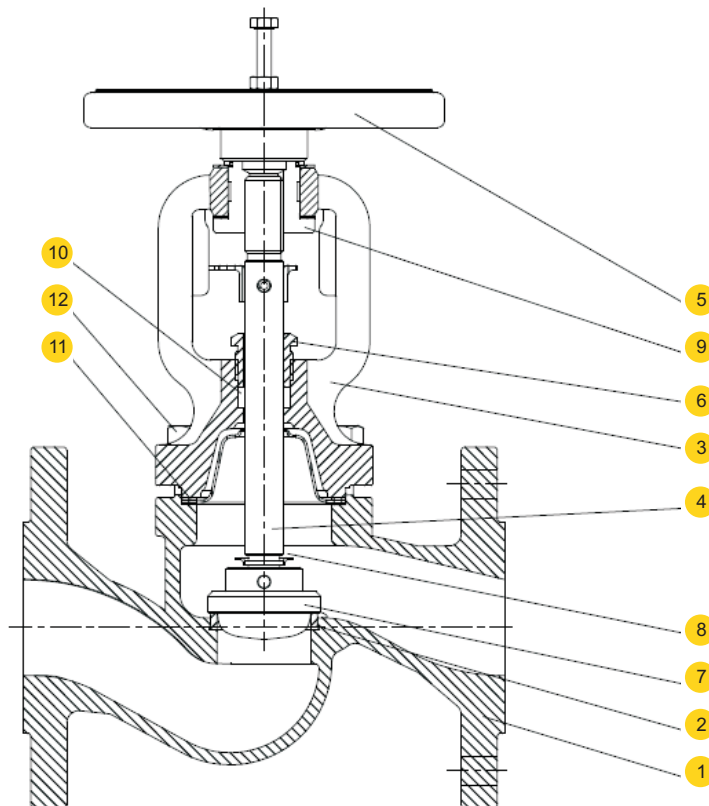
ends form flange
form straight

MATERIALS

type 01;04



type 71



Data given can be changed without notice.

Edition 04/2012

figure **234**

ends form flange straight

MATERIALS

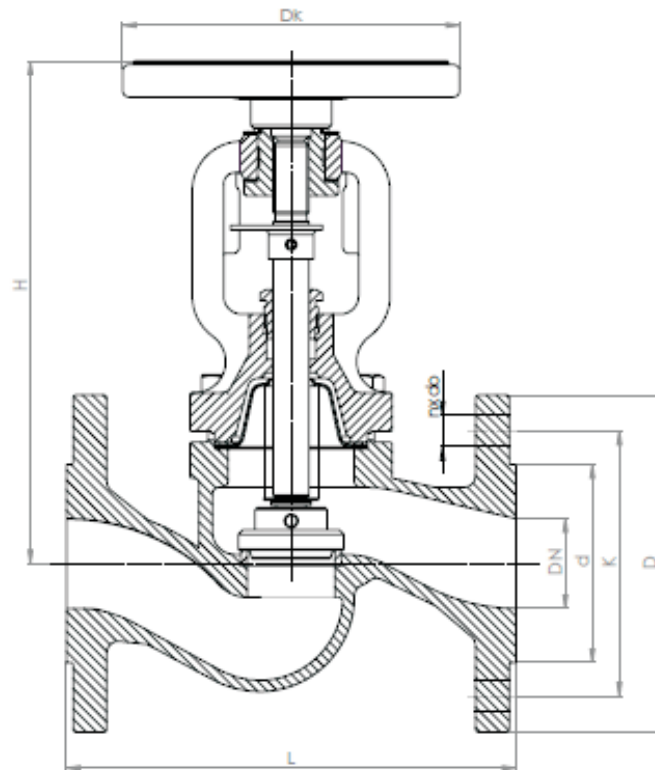
	body material	A	C
	type	01; 04; 71	01; 04; 71
1	body	EN – GJL-250 JL1040	EN – GJS400 - 18-LT JS1025
2	seat ring	X12Cr13 1.4006	
3	bonnet	EN – GJS400 - 18-LT Js1025	
4	stem	X20Cr13 1.4021	
5	hand-wheel	steel	
6	gland	11SMnPb30	
7	disc	X20Cr13 1.4021	
8	bellow	X6CrNiMoTi-17-12-2	
9	sleeve	11SMnPb30	
10	gland packing	graphite	
11	bonnet gasket	graphite+CrNiSt	
12	hexagon bolt	8.8	A2-70
	max. temperature	300°C	350°C



figure **234**

ends form flange straight

DIMENSIONS



DN	PN 16				PN 25				PN 16,25						type 71	
	D	d	K	n x do	D	d	K	n x do	Dk	h	L	H	Kvs		Kvs	
mm													m ³ /h	kg	m ³ /h	kg
15	95	46	65	4x14	95	46	65	4x14	125	5	130	178	5,9	3,2	3,4	3,2
20	105	56	75	4x14	105	56	75	4x14	125	5	150	178	7,4	3,9	6,3	3,9
25	115	65	85	4x14	115	65	85	4x14	125	7	160	193	13,0	4,6	9,4	5,0
32	140	76	100	4x19	140	76	100	4x19	125	8	180	201	18,0	6,5	16,0	6,7
40	150	84	110	4x19	150	84	110	4x19	150	10	200	224	30,0	9,0	26,0	9,3
50	165	99	125	4x19	165	99	125	4x19	150	13	230	228	41,0	11,0	40,0	11,5
65	185	118	145	4x19	185	118	145	8x19	175	17	290	270	79,0	15,8	70,0	16,3
80	200	132	160	8x19	200	132	160	8x19	200	20	310	295	115	20,5	106	21,4
100	220	156	180	8x19	235	156	190	8x23	250	25	350	321	181	35,0	170	36,0
125	250	184	210	8x19	270	184	220	8x28	300	32	400	388	225	49,0	245	51,5
150	285	211	240	8x23	300	211	250	8x28	400	38	480	448	364	76,0	360	78,0
200	340	266	295	12x23	360	274	310	12x28	500	50	600	575	725	130,5	-	130,5
250	405	319	355	12x28	-	-	-	-	500	63	730	645	-	210	-	-

Data given can be changed without notice.

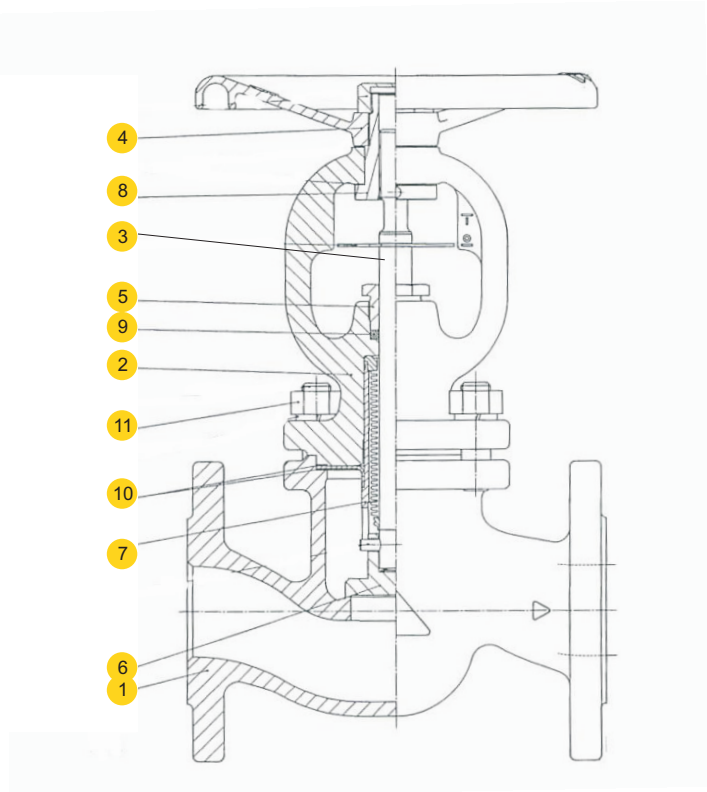
Edition 04/2012



figure **234**

ends form flange
form straight

MATERIALS



	body material	F
	type	01
1	body	GP240GH
2	bonnet	GP240GH
3	stem	X8CrNiS18-9 1.4305
4	hand-wheel	cast iron
5	gland	11SMnPb30
6	disc	X20Cr13 1.4021
7	bellow	X6CrNiTi-18-10
8	sleeve	11SMnPb30
9	gland packing	graphite
10	bonnet gasket	graphite+CrNiSt
11	bolt and nut	A2-70
	max. temperature	400°C

Data given can be changed without notice.

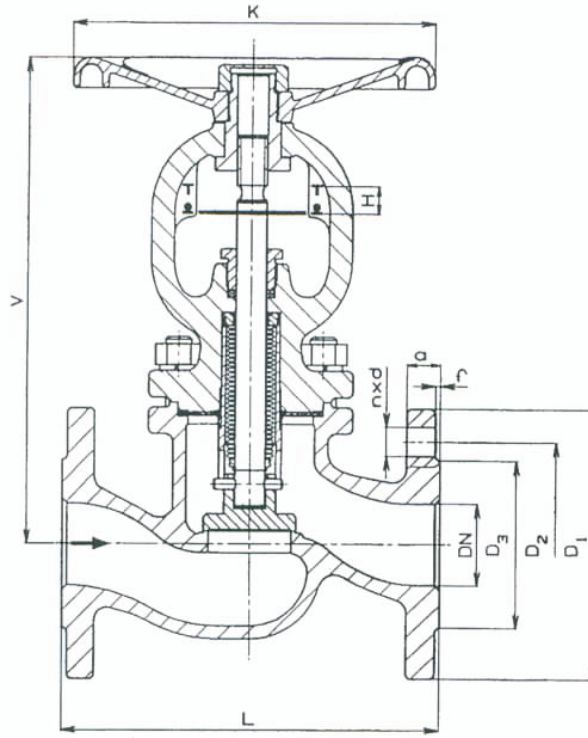
Edition 04/2012



figure **234**

ends form flange straight

DIMENSIONS



DN	PN 40										Kvs m ³ /h	
	D1	D3	D2	n x d	K	H	L	V	a	DN		
15	95	45	65	4x14	120	6	130	189	16	4,3	4,3	
20	105	58	75	4x14	120	6	150	189	18	7,0	5,1	
25	115	68	85	4x14	120	6	160	189	18	11,0	5,8	
32	140	78	100	4x18	160	10	180	220	18	17,5	9,5	
40	150	88	110	4x18	160	10	200	220	18	27,0	9,8	
50	165	102	125	4x18	195	16,5	230	295	20	47,0	17,5	
65	185	122	145	8x18	195	16,5	290	295	22	68,0	20,5	
80	200	138	160	8x18	280	25	310	368	24	116	34,0	
100	235	162	190	8x22	280	25	350	368	24	162	44,0	
125	270	188	220	8x26	350	40	400	523	26	250	77,0	
150	300	218	250	8x26	350	40	480	523	28	364	110	

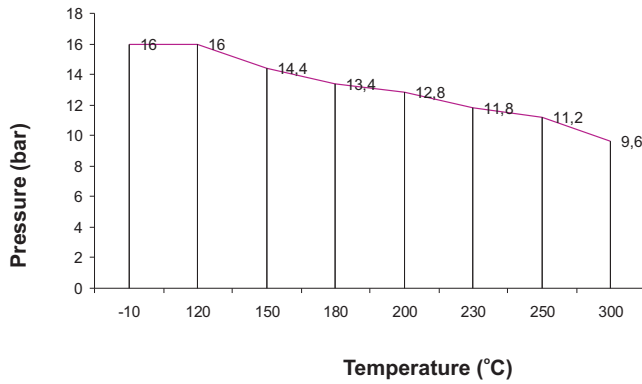
Data given can be changed without notice.

Edition 04/2012

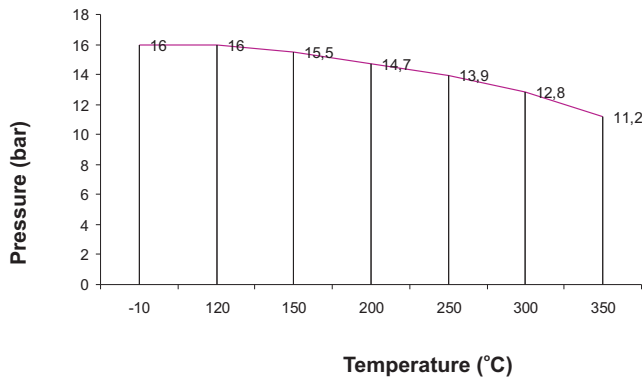


figure **234**
ends form flange straight

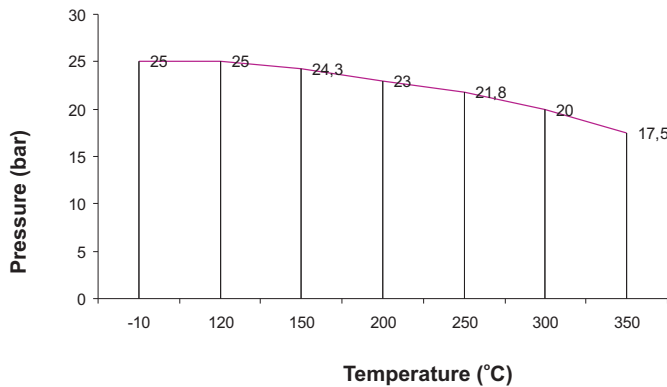
PRESSURE-TEMPERATURE RATINGS



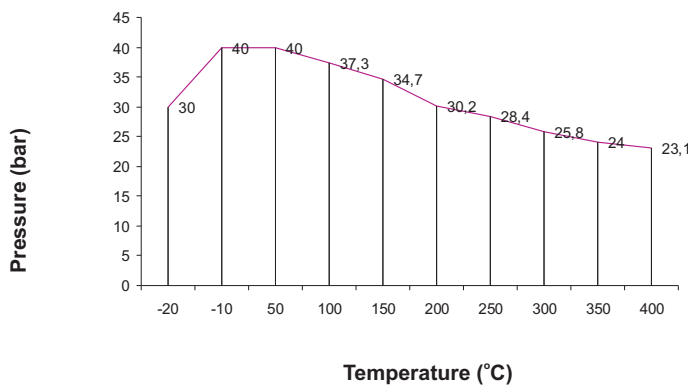
Allowed working conditions range
PN 16 EN-GJL-250



Allowed working conditions range
PN 16 EN-GJS-400-18-LT



Allowed working conditions range
PN 25 EN-GJS-400-18-LT



Allowed working conditions range
PN 40 GP24GH 1.0619

Data given can be changed without notice.

Edition 04/2012



figure 234
ends form flange straight

TYPES

figure	body material	nominal diameter DN	nominal pressure PN	type
234	A grey cast iron EN-GJL-250	15-150 mm	C 16bar	01 Tmax 300 °C * stem connected with bellow * stem, disc, bellow and seat ring - stainless steel
		200-250 mm	C 16bar	04 Tmax 300 °C * stem connected with bellow * stem, balancing disc, bellow and seat ring - stainless steel
		15-200 mm	C 16bar	71 Tmax 300 °C * stem connected with bellow * stem, throttling disc, bellow and seat ring - stainless steel
	C nodular cast iron EN-GJS-400-18-LT	15-150 mm	C 16bar	01 Tmax 350 °C * stem connected with bellow * stem, disc, bellow and seat ring - stainless steel
		200 mm	C 16bar	04 Tmax 350 °C * stem connected with bellow * stem, balancing disc, bellow and seat ring - stainless steel
		15-200 mm	C 16bar	71 Tmax 350 °C * stem connected with bellow * stem, throttling disc, bellow and seat ring - stainless steel
		15-150 mm	D 25bar	01 Tmax 350 °C * stem connected with bellow * stem, disc, bellow and seat ring - stainless steel
		200 mm	D 25bar	04 Tmax 350 °C * stem connected with bellow * stem, balancing disc, bellow and seat ring - stainless steel
		15-200 mm	D 25bar	71 Tmax 350 °C * stem connected with bellow * stem, throttling disc, bellow and seat ring - stainless steel
	F cast steel GP240GH 1.0619	15-150 mm	E 40bar	01 Tmax 400 °C * stem connected with bellow * stem, disc, bellow and seat ring - stainless steel

Data given can be changed without notice.

Edition 04/2012



figure	234
ends form	flange straight

ORDERING

To place an order please use our product number (index)



ORDER EXAMPLE

